



REFERENCE SPECIFICATION

Customer: Common

Item	Crystal Clock Oscillators
Type	NZ2520SB
Nominal Frequency	50 MHz
Customer's Spec. No.	-----
NDK Spec. No.	NSA3415E

For your reference we submit this specification. Please study and keep in your related document file.

Charge

Sales	NDK-I S.Coco	Tel. +39-02-96702920
Engineer	Engineering Dept.2 Y.Oishi	Tel. +81-4-2900-6662

Approved	C.Ishimaru
Checked	-----
Drawn	Y.Oishi

Revision Record

Rev.	Rev. Date	Item	Contents	Remarks
----	28.Nov.2012	Issue		

1. Type
NZ2520SB
2. NDK Spec. No.
NSA3415E
3. Maximum Ratings
 - 3.1 Supply Voltage (V_{CC})
-0.5 ~ +4.0 V DC
 - 3.2 Storage Temp.
-55 ~ +125 °C

4. Operating Temp. Range
-40 ~ +85 °C

5. Performance

- 5.1 Nominal Frequency
50 MHz
- 5.2 Standard Supply Voltage (V_{CC})
DC +3.3V ± 10 %
- 5.3 Current Consumption

Operating: See below table. (at 3.3V, 25°C)

Freq. range (MHz)	1.5≤F<10	10≤F<20	20≤F<30	30≤F<40	40≤F<50	50≤F<60	60≤F<70	70≤F≤80
Current consumption (mA)	3.5 Max.	4.0 Max.	4.5 Max.	5.5 Max.	6.0 Max.	7.0 Max.	8.0 Max.	9.0 Max.

Stand-by: 10µA Max. (at 3.3V, 25°C)

- 5.4 Output Level
C-MOS
- 5.5 Load Capacitance
15pF

6. Electrical characteristics

- 6.1 Frequency Stability (Inclusive of 25°C tolerance, temp. characteristics, and supply voltage change)
±50×10⁻⁶ Max.
- 6.2 Output Voltage
 V_{OL} : 0.1 V_{CC} Max.
 V_{OH} : 0.9 V_{CC} Min.
- 6.3 Rise Time(T_r) / Fall Time(T_f)
5ns max. (0.1 V_{CC} ~0.9 V_{CC})
- 6.4 Symmetry
45 ~ 55 % (at 1/2 V_{CC})
- 6.5 Output Wave Form
Rectangular
- 6.6 Start-up Time
4ms max.
- 6.7 Stand-by Function

#1 PAD input	# 3 PAD output
H level (0.7 V_{CC} ~ V_{CC}) or open	Operating
L level (0.3 V_{CC} max)	High impedance

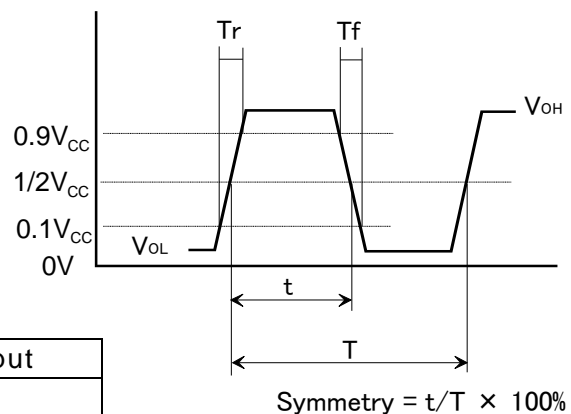

7. Measuring circuits

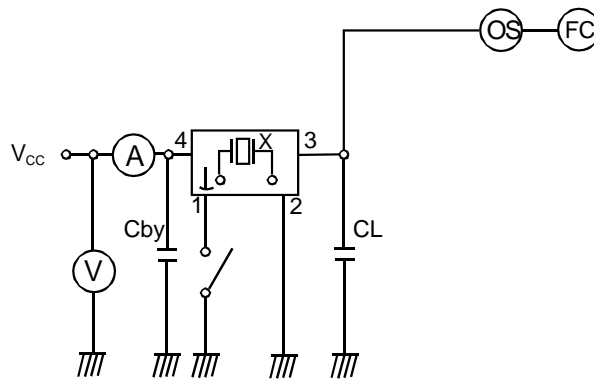

CL ; 15pF MAX including input capacity of oscilloscope
Cby ; Bypass capacitor (0.01uF)

8. Test data will not be submitted

9. Application drawing

9.1 Dimension drawing

EKD14B-00027

9.2 Marking drawing

EKH11B-00052

9.3 Reliability assurance Item

EKS30B-00060

9.4 Taping & Reel drawing

EKK17B-00032

EEK17B-00015

10. Instruction Notice

10.1 Noise

When the NZ2520S series are used, the 0.01 μ F capacitor should be connected between V_{CC} and GND line. (Closer to the product terminal is desirable.)

10.2 Resistance to dropping

The NZ2520S series is designed to be impactproof so that no damage occurs. However, if dropped from a desk etc., it is advisable to check their performance or contact us to check it.

10.3 Electrostatic protection

The NZ2520S series employ C-MOS ICs for the active element. Please use them in static-free environments.

10.4 High temperature

Normal operation cannot be guaranteed for the NZ2520S series at +125°C(for 24 hours).Be sure that the units are kept within the specified temperature range.

10.5 Cleaning

Basically, the NZ2520S series are applicable for ultrasonic wave cleaning. However, in some case, during ultrasonic wave cleanings, internal design may get damage. Please check condition carefully beforehand.

10.6 Other

The NZ2520S series are C-MOS applied products. And careful handling(same as with C-MOS IC) are needed to avoid electrostatic problems.

Incorrect PAD connection is cause of trouble. Please make sure to connect correctly as below.

#2 terminal \rightarrow GND

#4 terminal $\rightarrow V_{CC}$

11. Order items are manufactured according to specification. As to conditions, which are not indicated in this specification and unpredictable such as applied condition and oscillation margin, please check them beforehand.

*Example For Soldering Conditions (The below graph corresponds to Pb free solder)

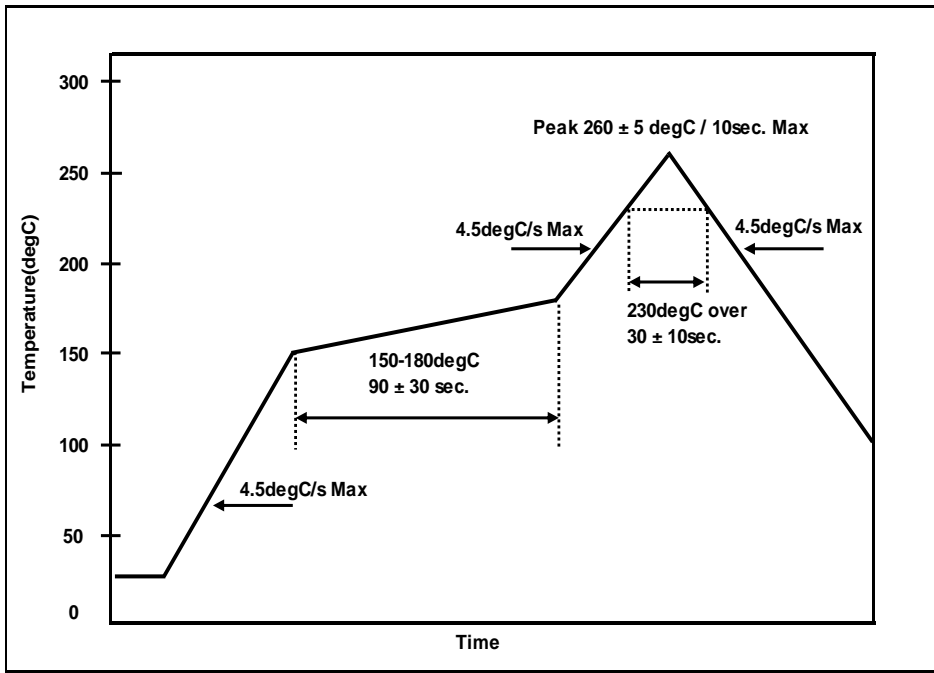

Recommended Footprint

[mm]

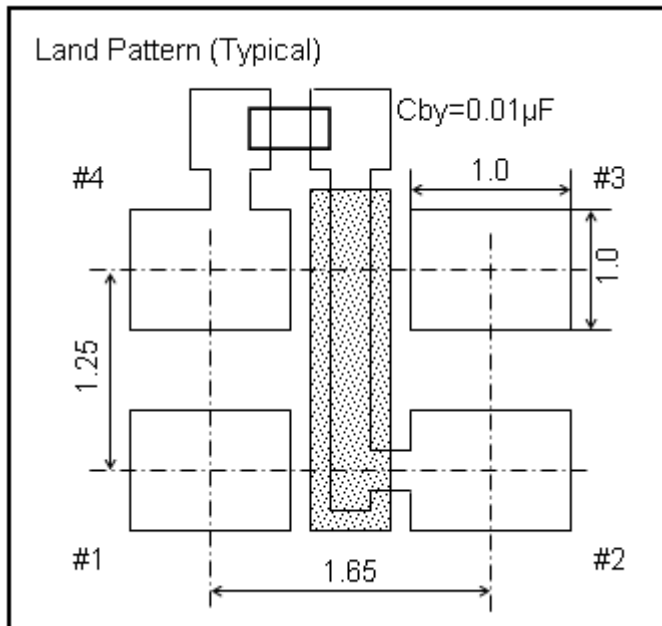

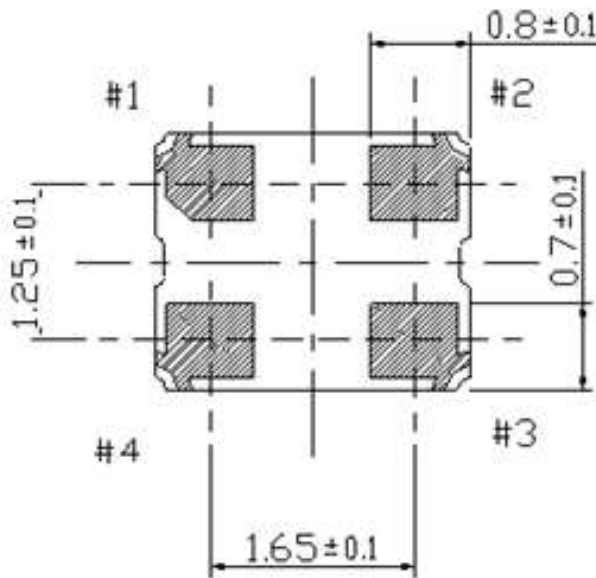
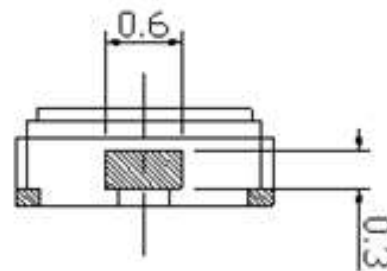
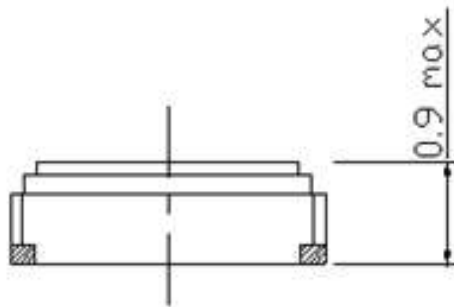
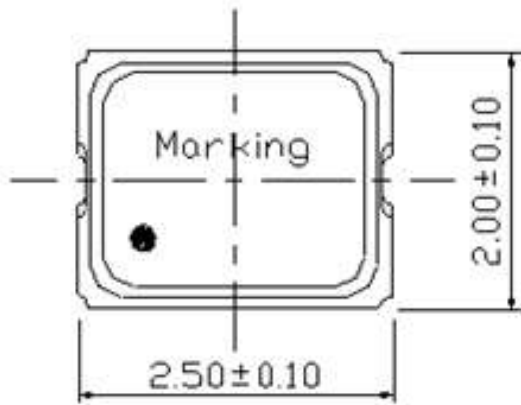

Terminal land connections

#1	STAND-BY
#2	GND
#3	OUTPUT
#4	V _{CC}

	Date of Revise	Charge	Approved	Reason	
C	2.Aug.2012	Y.Oishi	C.Ishimaru	Change V _{DD} →V _{CC} , PAD CONNECTIONS→Terminal land connections	
	Date	Name	Third Angle Projection	Tolerance	
Drawn	23.Oct.2003	M.Yamaguchi	Dimension : mm	-----	
Designed	27.Jun.2003	M.Yamaguchi	Title NZ2520S Dimension of External	Drawing No. EKD14B-00027	
Checked	-----	-----			Rev.
Approved	23.Oct.2003	H.Omata			C

NIHON DEMPA KOGYO CO., LTD.

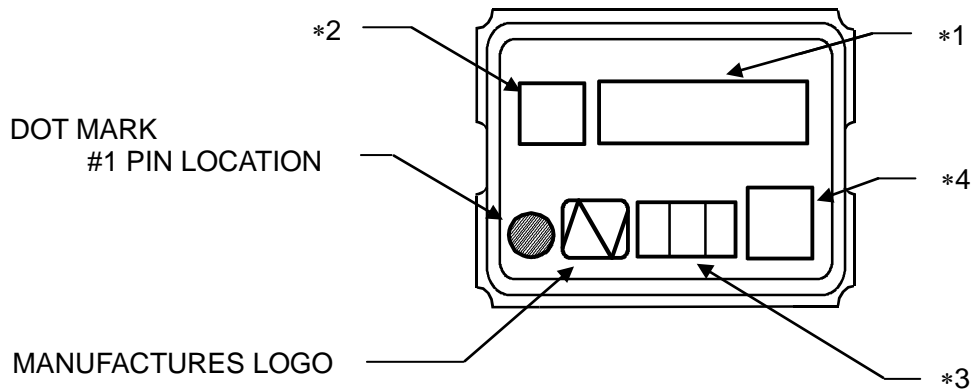

***1 [FREQUENCY]**

Digits are five and 6TH digit will be omitted.
 MHz unit sign is not marked.
 ex,) 28.63636MHz → 28.636 [Unit sign not marked]

***2 [MODEL MARK]**

A last digit of model is marked. →

[MODEL MARK]	
NZ2520SA	→ Space
NZ2520SB	→ B
NZ2520SC	→ C
NZ2520SD	→ D
NZ2520SEA	→ E
NZ2520SF	→ F
NZ2520SG	→ G

***3 [WEEK CODE (Digit are three)]**

ex1,) In case of 7TH week of 2006

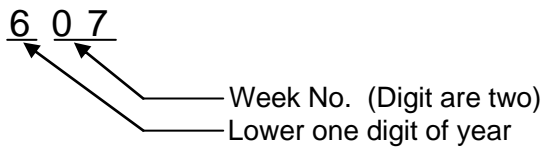

ex2,) In case of 31TH week of 2006

6 3 1

***4 [Trace code]**

Trace code consists of four digits number or letter.
 This code indicates production date and production line number.

Date of Revise	Charge	Approved	Reason				
F	30.Mar.2011	Y.Oishi	C.Ishimaru	Model mark change.(NZ2520SE→NZ2520SEA)			
Drawn	Date	Name	Third Angle Projection	Tolerance	Scale		
27.Jan.2006	Y.Oishi	mm	-----	-----			
Designed	Date	Name	Title	Drawing No.	Rev.		
27.Jan.2006	Y.Okajima	NZ2520S Marking				EKH11B-00052	F
27.Jan.2006	C.Ishimaru						
27.Jan.2006	H.Omata						

NIHON DEMPA KOGYO CO., LTD.

Environmental Test Conditions	Specification
1. Thermal Shock Test 1 cycle: -40°C (30 minutes) ~ +85°C(30 minutes) Number of cycle: 100 cycle.	*1
2. High Temperature High Humidity Test Temperature : +85°C, Humidity : 80 ~ 85%, Time : 250 hours.	*1
3. +85°C Aging (Non Operating) Temperature : +85°C, Time : 500 Hours.	*1
4. Vibration Test MIL-STD-202F test method: 204D Test condition : D 10 ~ 2000Hz, 1.52mmp-p, or 196m/s ² 20 minutes/cycle, XYZ 3 directions 4 times.	*1
5. Shock Test MIL-STD-202F test method : 213B Test condition : Half sinusoidal wave 29400m/s ² , 0.3ms, 3 directions, 3 times each.	*1
6. Drop Test (JIG attachment) Dummy load : 200g, Height : 1.5m, Fall conditions : On concrete The number of times of fall : Six directions and 1 time each are made into 1 cycle, and it is 10 cycle.	*1
7. Soldering Test (Reflow) Pre heat : 150±10°C, 60~120sec. Main heat : 30±1 seconds after amounting to 215 °C. Peak temperature : 240°C	More than 90% of should be covered by solder.
8. Soldering Resistance (Reflow) Pre heat : 180±10°C, 120 sec min, Main heat : 225°C min, 70sec max. Peak temperature : 260°C . Reflow time : 3 times.	*1
<p>*1 After the test mentioned above, the electrical specifications are satisfied. Also frequency deviation before and after test should be</p> $\Delta F/F \leq \pm 10 \times 10^{-6}$ <p>The electrical specifications are I_{CC}, T_r/T_f, V_{OL}/V_{OH}, duty cycle, stand-by function, stand-by current consumption.</p>	

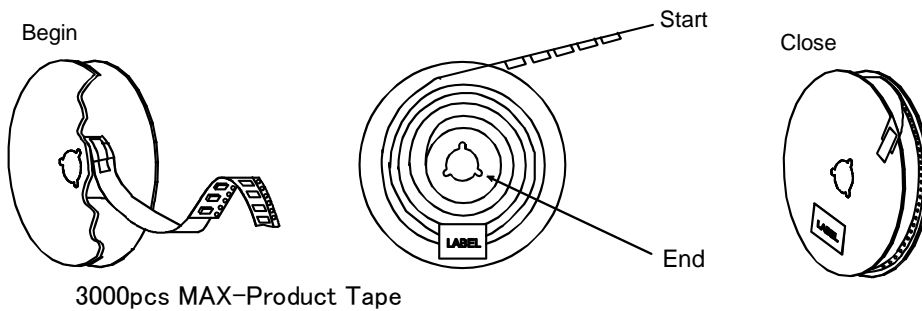
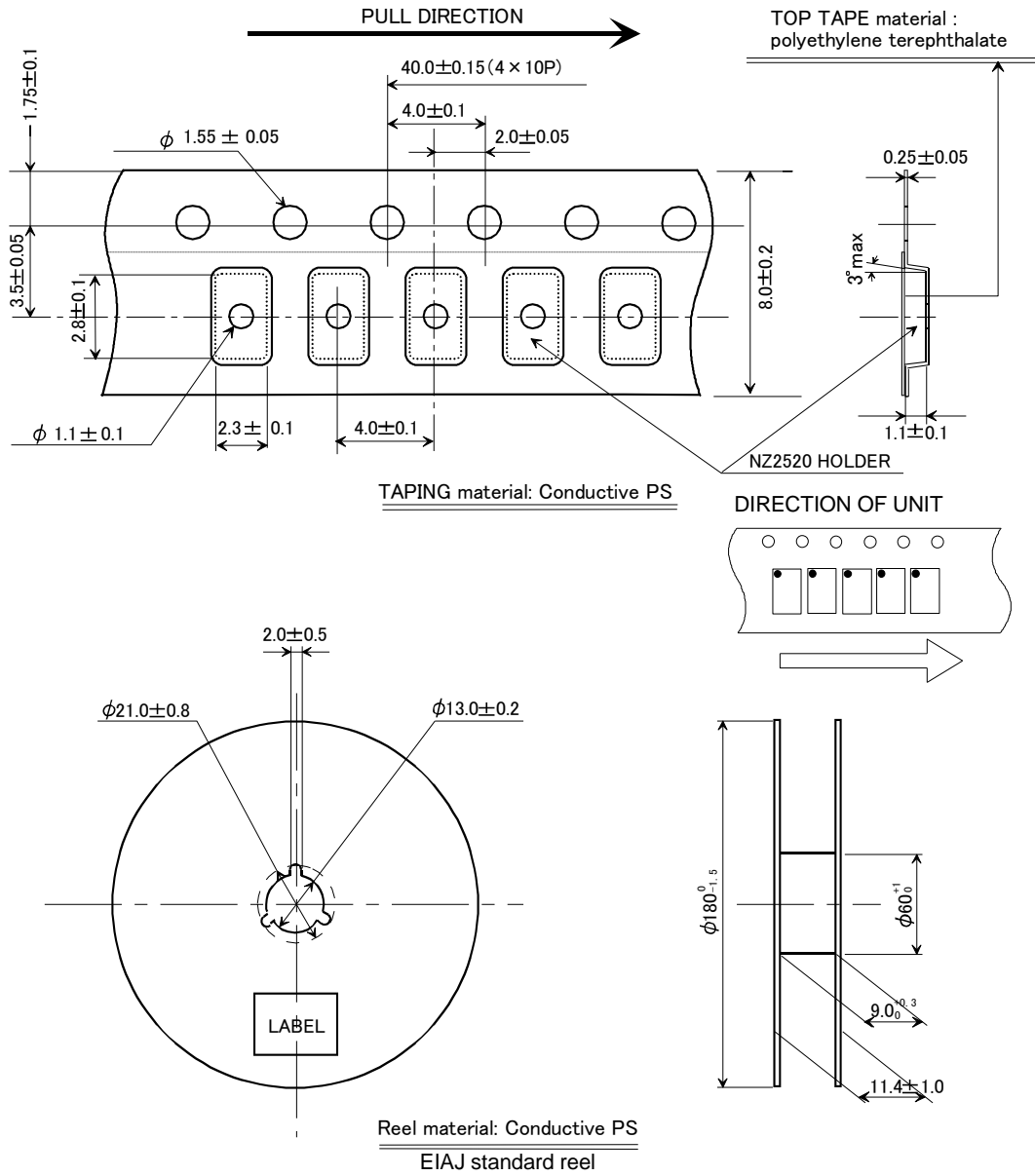

	Date of Revise	Charge	Approved	Reason
C	5.Sep.2012	Y.Oishi	C.Ishimaru	3000pcs-Product Tape→3000pcs MAX-Product Tape.
	Date	Name	Third Angle Projection	Tolerance
Drawn	7.Oct.2003	Y.Okajima	Dimension:mm	Scale
Designed	7.Oct.2003	Y.Okajima	Title	Rev.
Checked			NZ2520 Taping and Reel Spec.	EKK17B-00032
Approved	7.Oct.2003	H.Omata		

NIHON DEMPA KOGYO CO., LTD.